

2nd Edition



e future

S
Starter

Contents



Unit 1 My Things 6

Unit 2 My Classroom 12

School Link 1 Coloring 18

Unit 3 Fun Colors 20

Unit 4 Shapes 26

School Link 2 Weather 32

Unit 5 Numbers 34

Unit 6 My Body 40

School Link 3 Numbers 46





Unit 7 My Toys 48

Unit 8 My Pets 54

School Link 4 Addition 60

Unit 9 My Actions 62

Unit 10 More Actions 68

School Link 5 Telling Time 74

Unit 11 My Snacks 76

Unit 12 My Feelings 82

School Link 6 Rules 88



Scope and Sequence 90

Key Words 92

Characters

Joey Jones



Sunny



Jade Chen



Matt Lewis



Jumbo



Mila Lopez



Ditto



Fluffy



Theme Song 1

What's up?
Let's get together.
Everybody!
Are you ready to have fun?
Come along and join with us.
We'll have so much fun!
Come along! Hand in Hand!

2x



A

Hello. How are you?
I'm great. How are you?
I'm ready to learn with you.
I'm ready! Let's get started!

We'll go Hand in Hand
To our own wonderland.
You and me.
We'll go together Hand in Hand.

It's English for yourself.
English for the world.
You can do it with Hand in Hand.
Come along! It's lots of fun.
You can with Hand in Hand.

Repeat **A**.



Conversation

A Listen and repeat. Then act out with friends.   

Hello. I'm Mila.

Hi. I'm Joey.

Hello. I'm Matt.

Hi. I'm Jade.

B Listen and sing.  



Hello! Hi!

Hi. I'm Jade.
Hello. I am Matt.

Hello.
Hello.

Hi! I am Mila.
Hello! Hello!

Hi! I am Joey.
Hello! Hello!

C Listen and repeat. Then say. 

1

Hi. I'm Ditto.



2

Hello. I'm Fluffy.



3

Hello. I'm _____.



Words and Sentences

A Listen and repeat. Then point and say. 

1



bag

2



book

3



crayon

4

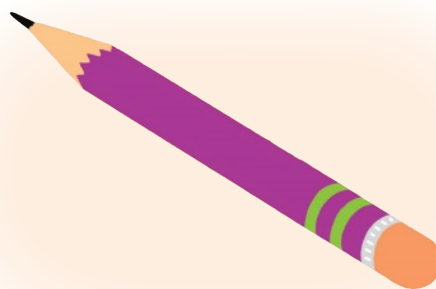

pencil

B Listen and chant.  

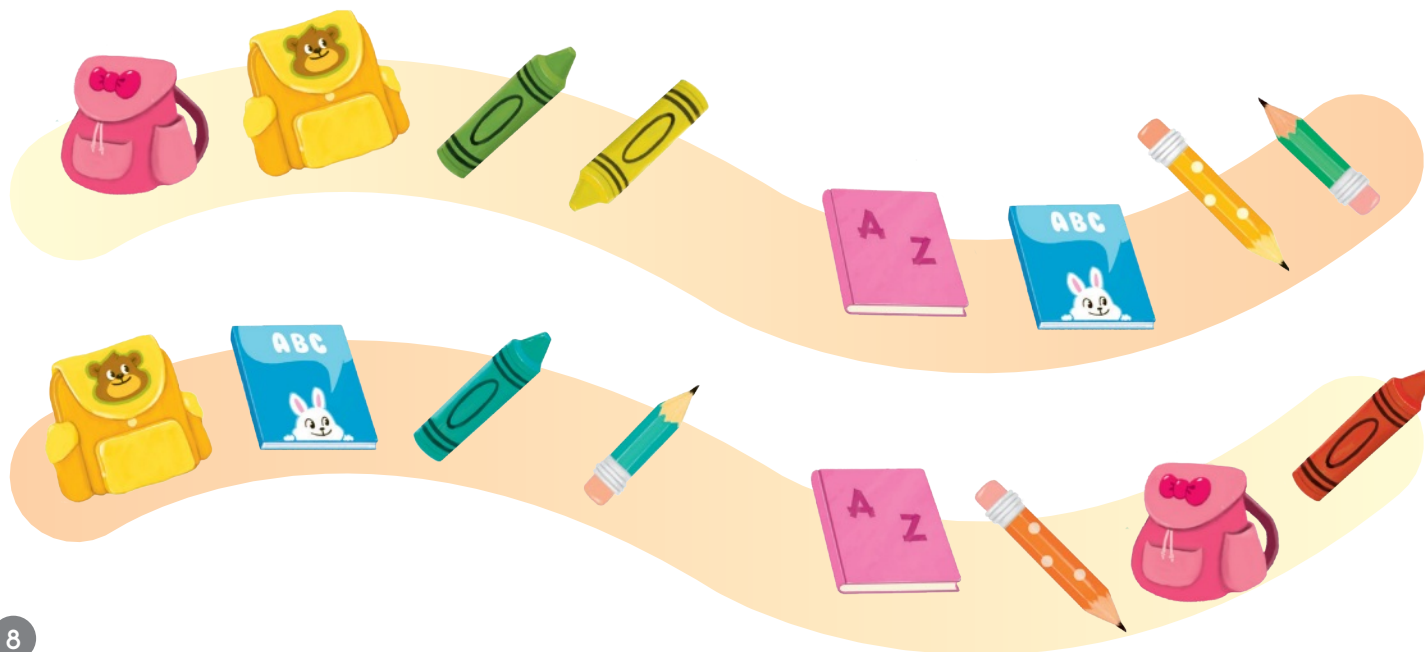

C Listen and repeat. Then ask and answer. 7



Unit Link U1

A Listen and answer. 8

1



2

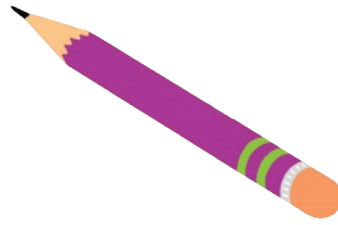

3



B Find and say.

This is a book.



English Sounds

● Listen and sing along.  

Aa



Bb



Cc



Dd

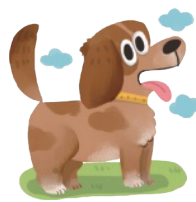

Ee



Ff



Gg



Hh



Ii



Jj



Kk



Ll



Mm



Nn



Oo



Pp



Qq



Rr



Ss

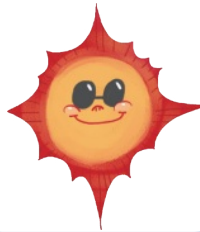

Tt



Uu



Vv



Ww



Xx



Yy





Zz



School Link 1

Story

● Listen and point. Then look and read.  

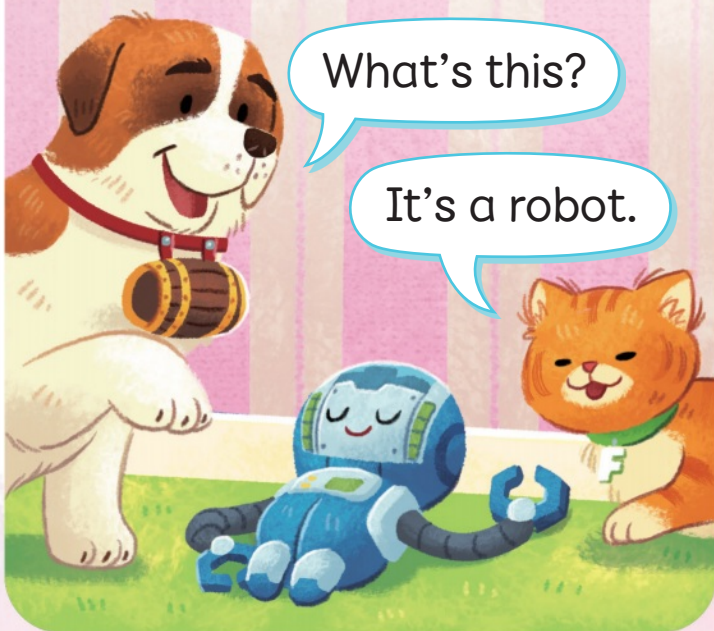

Coloring

- Look and listen. Then color. 20

1 This is a **book**.

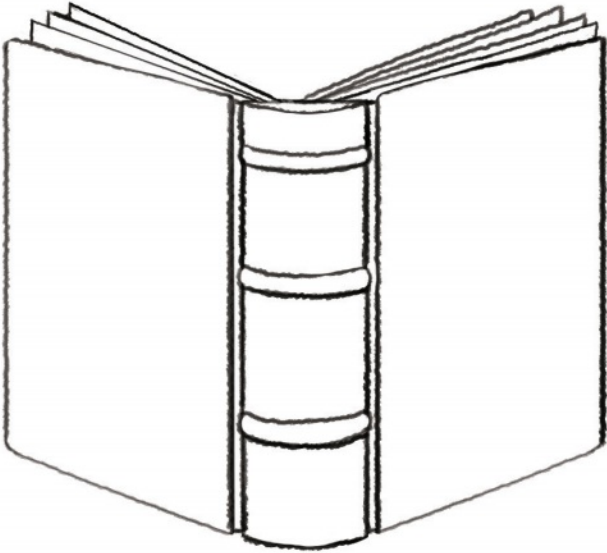

2 This is a **pencil**.

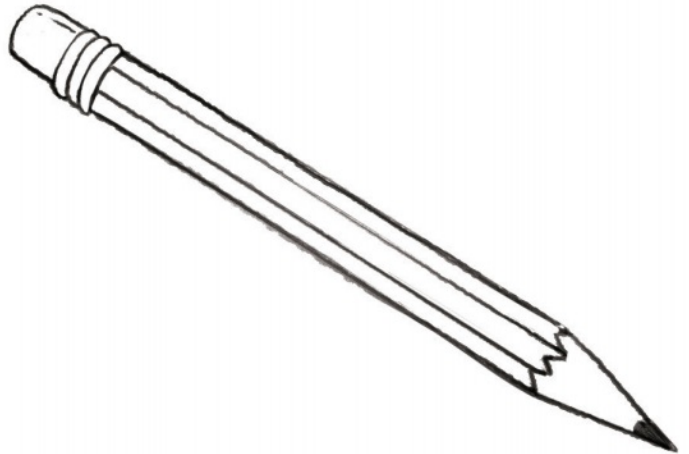

3 This is a **board**.

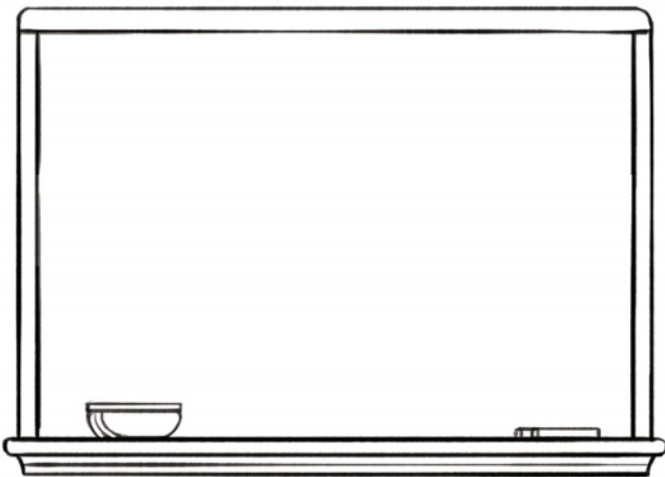

4 This is a **chair**.

